

# F7\_F707\_F708

## Access Control Terminal

---

### Installation Instructions



*Revised May 2008*

#### **About this Guide**

This guide provides installation instructions only. For information regarding actual operation and configuration of the F7\_F707\_F708 Time & Attendance and Access Control Terminal, refer to the user manual.

## Table of Contents

<b>Before Installation .....</b>	<b>1</b>
<b>Front and Read Panel views .....</b>	<b>5</b>
<b>Optional 3<sup>rd</sup> Party Equipment.....</b>	<b>6</b>
<b>1.0 Installation.....</b>	<b>7</b>
1.1 Attaching Mounting Plate.....	7
1.2 Connecting Power Supply.....	9
1.3 Selecting Door Lock.....	10
1.4 Connecting an electric strike or magnetic lock.....	11
1.5 Powering Door Lock.....	13
1.6 Connecting switches, door sensor, doorbell, etc.....	14
1.7 Connecting 3 <sup>rd</sup> party door controller/panel.....	16
1.8 Connecting network or computer.....	17
<b>2.0 Testing.....</b>	<b>20</b>
2.1 Run Auto Test.....	20
2.2 Test Fingerprint Enrollment.....	23
<b>3.0 Fastening to mounting plate and wall.....</b>	<b>30</b>
<b>4.0 Miscellaneous.....</b>	<b>31</b>
<b>5.0 Trouble-shooting.....</b>	<b>32</b>

## Before Installation

1. Prior to beginning installation, **cut off all power** to prevent personal injury and damage to the F7\_F707\_F708 and peripheral equipment.
2. Connect the ground wire first, in order to prevent electro-static damage to the F7\_F707\_F708.
3. Connect 12V DC power supply to the F7\_F707\_F708 **last**.

If the F7\_F707\_F708 does not operate properly, **always cut off power to it** before examining/dismantling. Be advised that wiring the F7\_F707\_F708 while power is on may cause damage to the terminal. Possible resulting damage from not powering off the F7\_F707\_F708 prior to wiring is not covered by manufacturer's warranty.

4. Mount the F7\_F707\_F708 at a comfortable height, typically between 4 and 5 feet from the ground.
5. After installation, remove protective film from the F7\_F707\_F708 display and fingerprint sensor.
6. To prevent being accidentally locked out while testing the exit-door button, keep a person on the inside of the door.
7. Run the auto-test function to confirm that installation is successful.

8. In order to maximize the life of the F7\_F707\_F708, use the auto-sleep and wake up functions.
9. ONLY use a **12V DC 1.5Amp** power supply for proper functioning of the F7\_F707\_F708 terminal. If the incorrect voltage is used, the F7\_F707\_F708 may keep rebooting or may not operate the electric door lock (if attached).
10. Improper wiring may cause the F7\_F707\_F708's main circuit board and fingerprint sensor to burn out. Resulting damage from improper wiring is not covered under manufacturer's warranty.
11. Only use supplied transformer and cord. Do not attempt extending the cord by cutting and splicing.
12. If using RS485 mode of communication, use only a ZK Software-supplied RS485 converters. Using a 3<sup>rd</sup> party RS485 converter may or may not work. If the RS485 cable length exceeds 200 feet, we recommend using a 120 $\Omega$  terminator.
13. Refer to the user handbook and operating instructions for further information.

Front panel view:





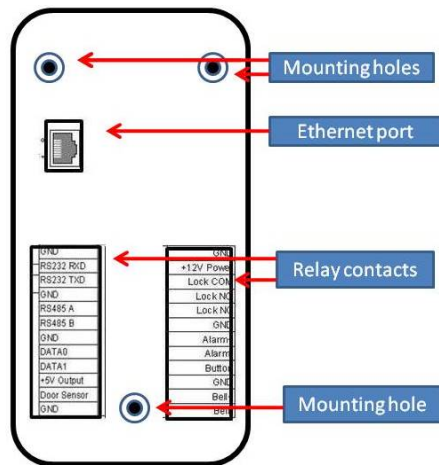





Rear panel view:



## Optional 3<sup>rd</sup> party equipment

The following equipment is not provided by ZK Software, but often compliments a complete Access Control solution;

Part	Image	Part	Image
PC		Door Lock	
Door sensor		Exit Button	
Alarm		RS485/ RS232 converter	
Door Controller		Network Cable	

## 1.0 Installation

### 1.1 Attach Mounting Plate

1. Take out the F7\_F707\_F708 fingerprint terminal and remove the screw (screwdriver supplied) which secures the F7\_F707\_F708 to its mounting plate;



2. Remove mounting plate by grasping the bottom edge and lifting it inward and upward.
3. Determine the position of mounting plate on the wall. We recommend about 4-5 feet from the ground so it is comfortably within reach of most of your users.

4. After its position is determined, cut-out square-openings in the walls which correspond to the cut-outs in the F7\_F707\_F708's mounting plate for wires to pass through;

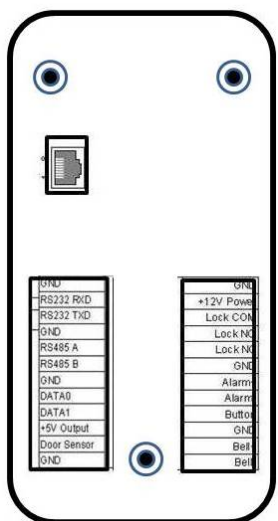

5. Use 3 mounting screws (supplied) to affix the F7\_F707\_F708 mounting plate on the wall.
6. Then secure the F7\_F707\_F708 to the mounting plate.



## 1.2 Connecting Power Supply

F7\_F707\_F708 operates on 12V DC Power supply and connect the positive and GND as shown below. If you are connecting a magnetic lock or an electric strike to F7\_F707\_F708 than we recommend it should draw maximum current of 1A. If you need more power than please use an external power supply of higher current capacity.

GND	GND	—12V DC + Power supply adapter
RS232 RXD	+12V Power	
RS232 TXD	Lock COM	
GND	Lock NO	
RS485 A	Lock NC	
RS485 B	GND	
GND	Alarm +	
DATA0	Alarm —	
DATA1	Button	
+5V Output	GND	
Door Sensor	Bell +	
GND	Bell —	

### **1.3 Selecting door lock**

For glass doors which swing both in and out, we recommend the use of electro-magnetic door strikes (aka “mag locks”).

For 1-way opening non-glass doors we recommend the use of electric door strikes, instead.

While both locks are equally secure, the mag lock is considered safer than the electric strike, especially during power interruptions. During a power failure caused by fire or other safety threats, the mag lock will “fail open” and allow people to exit a room/building unhampered.

Conversely, the electric strike “fails closed”. With loss of power you can still exit a door secured by an electric door strike. But you’ll need a mechanical device (i.e. door handle or exit bar) to free the door during power interruptions. ZK Software is not responsible for any personal injury or damage caused by power failure.

## 1.4 Connecting an electric strike or magnetic lock

F7\_F707\_F708 has NO and NC closed contacts for controlling the locks. Since there are many different types of locks available we recommend to connect these locks as per the recommendation of the manufacturers.

Ensure that proper voltages are applied to the lock terminals and check on the current ratings of the locks.

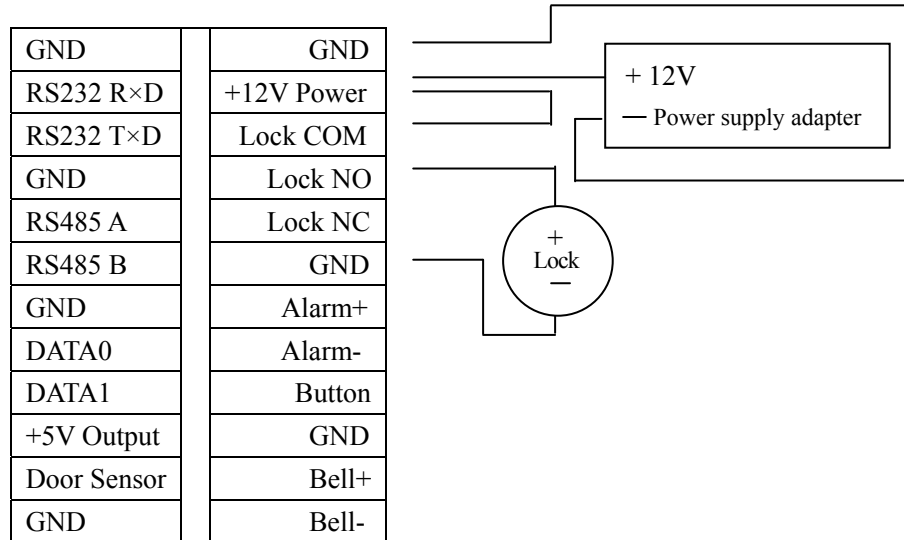

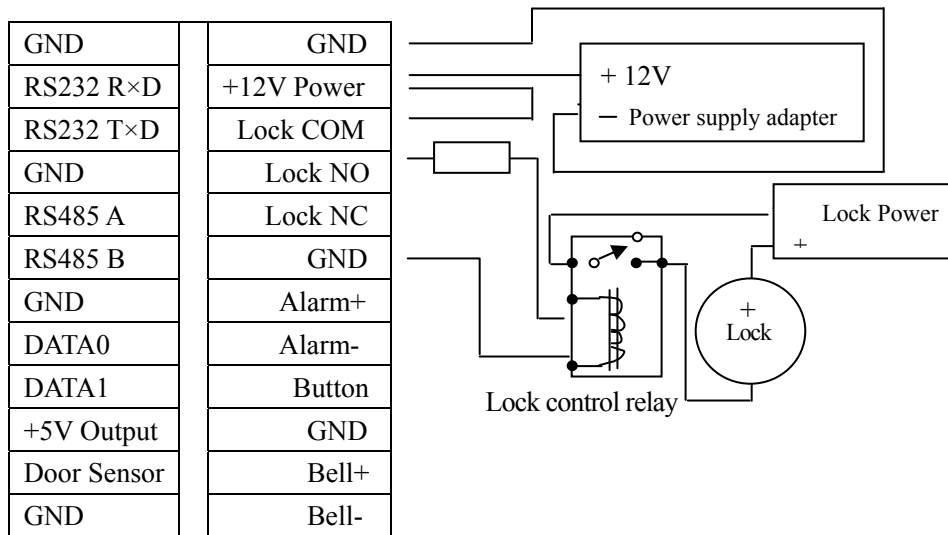
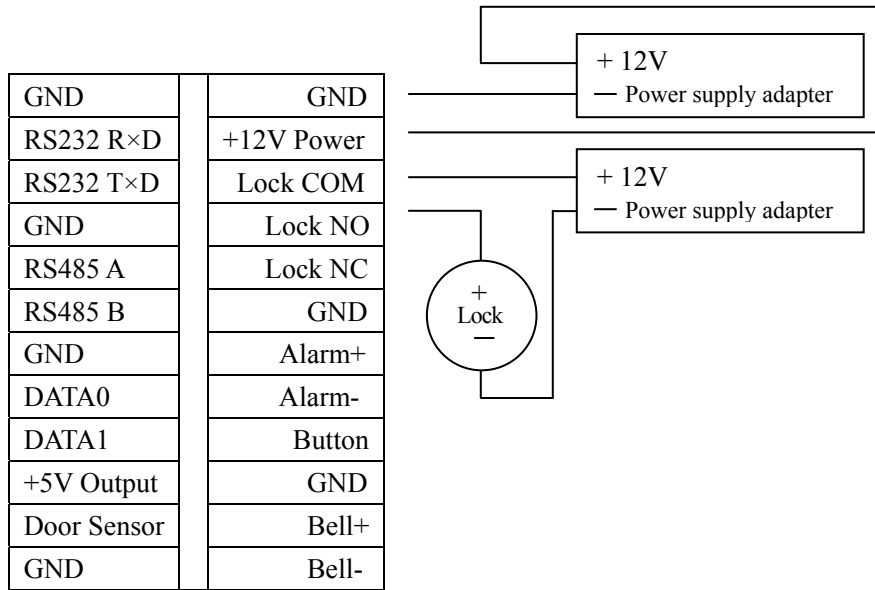

## **1.5 Powering Door Lock**

The F7\_F707\_F708 can supply power directly to a door lock.

However, in the following three scenarios, it is recommended that the door lock has an independent power source, and is NOT powered by the F7\_F707\_F708;

- If the door lock voltage is not 12V DC then provide separate power to the door lock.
- If the door lock runs on 12V DC, but requires more than 1A (amp), then provide separate power to the door lock.

If the distance between the F7\_F707\_F708 and door lock is greater than 15 feet, then provide separate power to the door

## 1.6 Connecting switches, door sensor, doorbell, etc.

You can connect the exit switch as shown below. This is mainly used for receptionists to open the door for the visitors. The door sensor switch is used to trigger the alarm if the door is kept open for more than specified time. Furthermore, F7\_F707\_F708 will also send an alert signal if the door is not closed within the specified time.

You can connect a doorbell to the F7\_F707\_F708 as shown below. Visitors can hit this button which will trigger the door bell inside the door.

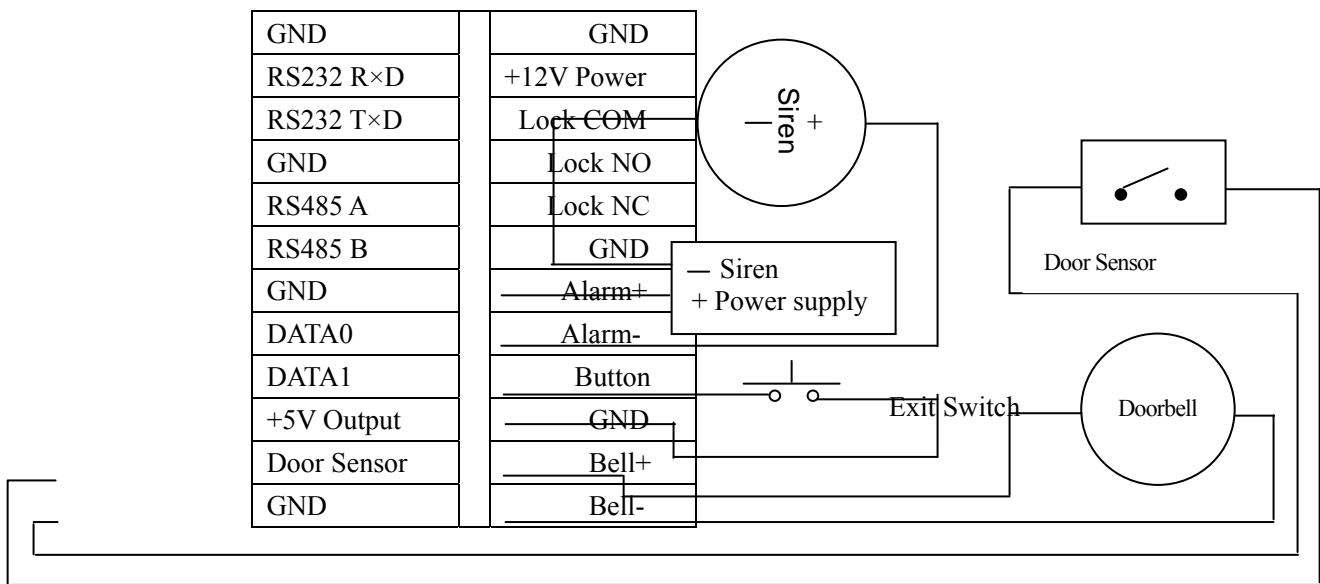

## 1.7 Connecting 3<sup>rd</sup> party door controller/panel

The F7\_F707\_F708 provides standard Wiegand 26-bit output, which can be connected to most 3<sup>rd</sup> party access control panels. The F7\_F707\_F708 connects to the panel just like any card-reader or keypad.

The distance from the controller to the F7\_F707\_F708 cannot be more than 16 feet. If the Wiegand signal must be transferred much further, or if electro-magnetic interference exists, utilize a Wiegand signal amplifier.

Use the following connections;

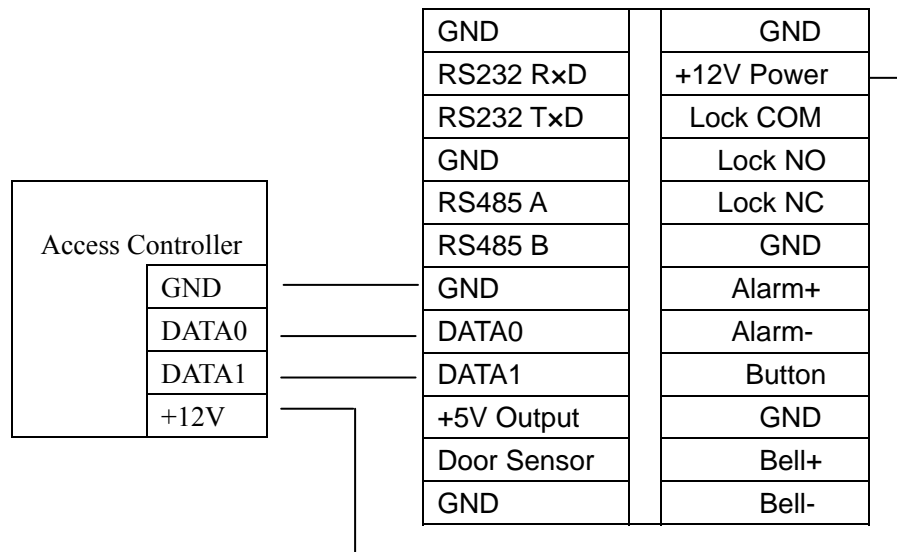

## 1.8 Connecting network or computer

F7\_F707\_F708 offers RS232 and RS485 interface, or Ethernet connectivity to connect with a computer network.

### Ethernet connection

**Option 1:** Direct connection to PC via **cross-over cable**;



**Option 2:** Indirect connection to PC via **network router**;

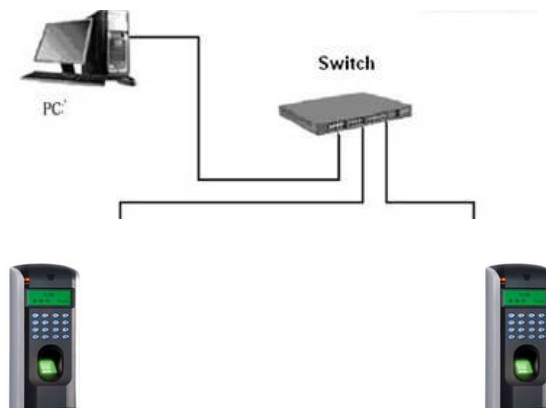



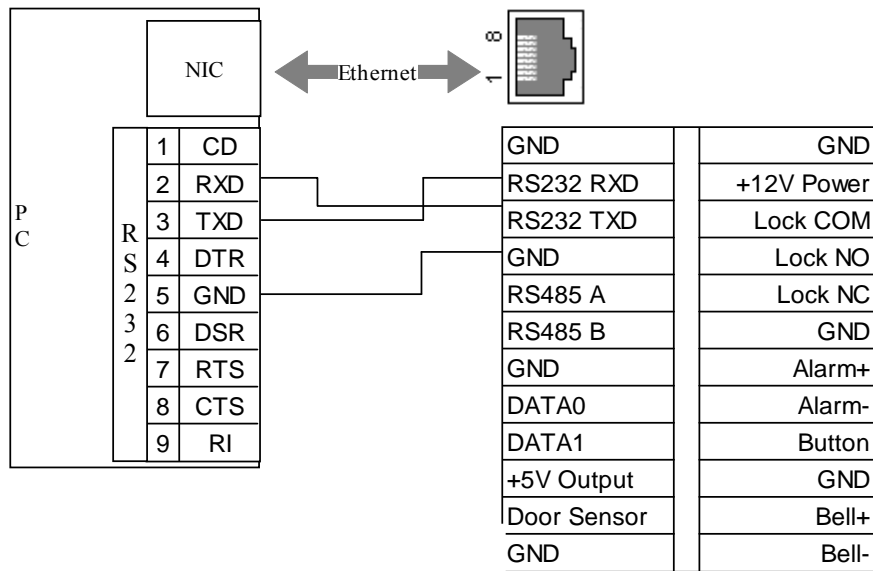

## **RS485 connection**

RS-485 systems using a bus structure configuration connect the driver to the receiver. The transmission line is made by a group of twisted-pair cables. Each cable has a pair of conductors consisting of inverted and non-inverted signal lines. The inverted line is generally designated by the letter "A" or "-", with the non-inverted line designated as "B" or "+". In order to eliminate or reduce "noise", traditional RS485 networks require a 12 $\Omega$  terminal resistor to be installed at the end of the bus cables based on the physical layout of the twisted-pair cables. In the normal condition the resistor is not installed, only if the bus is extended over 125 feet, the termination must be connected with a terminal resistor.

## 2.0 Test and examine after installation

With power on, test for the following:

- ✓ The green LED lights up after power up.
- ✓ 2.1 Run Auto-test;

Press the **M** (Menu) key on the F7.



Scroll with the ▲/▼ keys and place the cursor (▶) alongside **Options**.

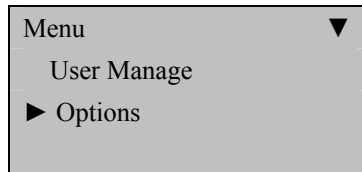

Press the **OK** key.



The Options Menu will appear;

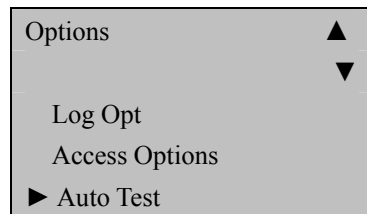

Scroll with the ▲/▼ keys and place the cursor (▶) alongside **Auto Test**.

Press the **OK** key.

The following screen appears;

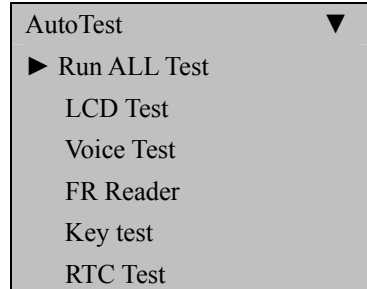

Scroll with the ▲/▼ keys and place the cursor (▶) alongside the feature you'd like to test and press the **OK** key.

When finished testing, continue pressing the **C** (Cancel/ESC) key repeatedly until you return to the Start-Up window.

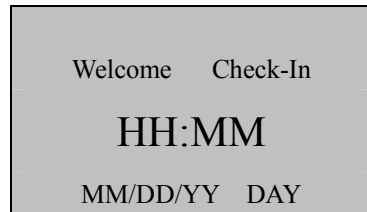

**Note:**

The actual current date/time will appear.

✓ 2.2 Test Fingerprint Enrollment;

Press the **M** (Menu) key on the F7.



Scroll with the ▲/▼ keys and place the cursor (▶) alongside **User Manage**

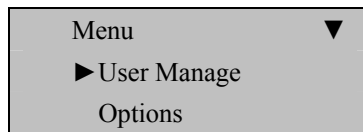

Press the **OK** key.



Scroll with the ▲/▼ keys and place the cursor (▶) alongside **Enroll User**.

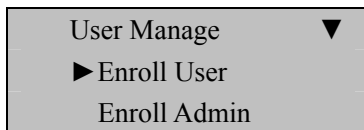

Press the **OK** key.

Scroll with the ▲/▼ keys and place the cursor (▶) alongside **Enroll FP**.

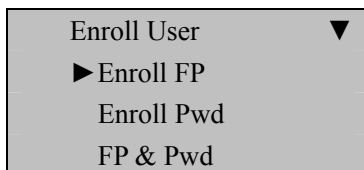

Press the **OK** key.

The F7 will prompt you;

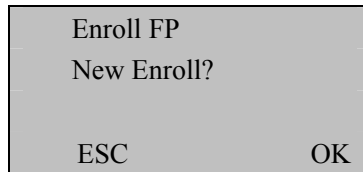

Enroll FP  
New Enroll?  
  
ESC OK

Press **OK**.

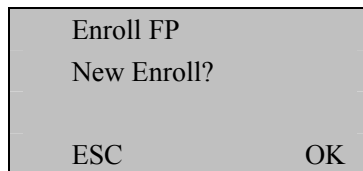

Enroll FP  
New Enroll?  
  
ESC OK

Since we are enrolling a New User, press **OK**

The F7 will then prompt you with the next available User ID;

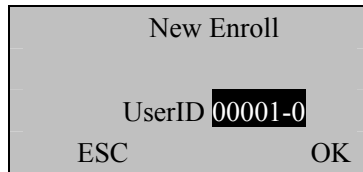

New Enroll  
  
UserID 00001-0  
  
ESC OK

In this example, no user has yet been enrolled on the F7. So the next available User ID# is 00001.



Press the **OK** key to accept 00001, or manually key in a different number if desired.

The F7 will then prompt;

New Enroll  
00001-0  
Place Finger . . .  
ESC/Exit

Remember the rules for proper finger placement;

The user's finger should completely cover the sensor. The finger should be placed flat and in the center of the sensor. The finger should cover at least 80% of the sensor as shown below:

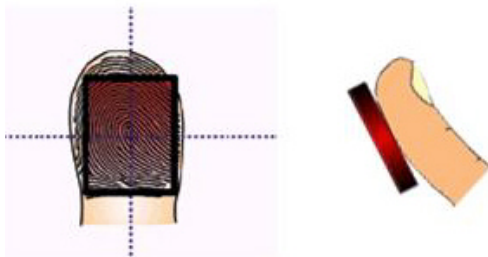

*The finger should NOT be placed in the following positions:*

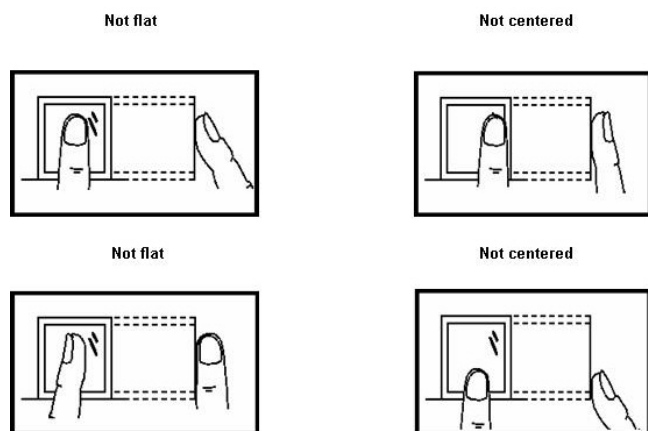

Place your finger on the sensor for a full 2 seconds.



After the F7 scans your fingerprint successfully, it will “beep” and then prompt you briefly with;

New Enroll  
00001-1  
Remove Finger  
ESC/Exit

Then you'll be prompted;

New Enroll  
00001-1  
Second Press  
ESC/Exit

Remove your finger, and then place your finger on the sensor a 2<sup>nd</sup> time. Again, you'll be prompted briefly;

New Enroll  
00001-1  
Remove Finger  
ESC/Exit

Remove your finger, and then place your finger on the sensor a 3<sup>rd</sup> and final time. You'll then be prompted;

New Enroll  
00001-0  
ESC OK (Save)

Press the **OK** key to accept the newly enrolled finger.

The F7 will then prompt you with;

New Enroll  
Continue?  
ESC OK

UserID 0001 has now been successfully enrolled with one fingerprint.

If you wish to continue enrolling additional users, press the **OK** key and follow the same procedures.

If you're finished enrolling additional users, press the **C** (ESC/cancel) key repeatedly, until you return the Start-Up window;

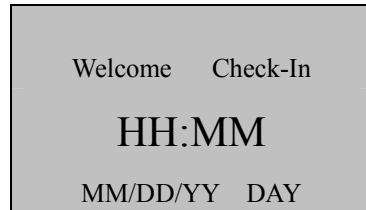

**Note:**

The actual current date/time will appear.

Test the newly enrolled fingerprint by having UserID 00001 place his/her finger on the sensor.

If successful, the F7 will respond with an audible “*Thank you*”, and the screen will display;

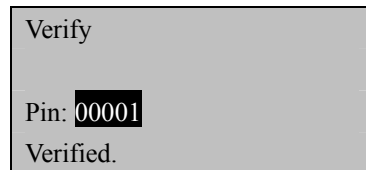

### 3.0 Fasten F7\_F707\_F708 to mounting plate/wall

- ✓ Confirm all connecting wires are correct and securely fastened.
- ✓ Properly align the rear metal-plate of the F7\_F707\_F708 to the mounting plate and then push up on it. Then push the F7\_F707\_F708 backwards. The F7\_F707\_F708 is now securely affixed to the mounting plate and wall.



- ✓ Tighten screw on underside of F7\_F707\_F708.



## 4.0 Miscellaneous

### 4.1 Reset

#### IMPORTANT NOTE

Resetting the F7\_F707\_F708 does NOT erase any stored data (i.e. templates, transactions, settings). This information will be available as soon as power is restored.

To reset the F7\_F707\_F708 use a small tool (e.g., pin or paperclip) to push in the reset button (labelled “reset”) located on the underside of the F7\_F707\_F708 (see figure below).



### 4.2 Tamper-proof button

When the F7\_F707\_F708 detects it is being “tampered” with, it will send an alarm signal.

## 5.0 Trouble shooting

Trouble	Cause & Fix
Power LED is off	<p><b>Cause :</b> No power or lack of voltage</p> <p><b>Fix:</b> Check and examine power and ground connections. Also ensure 12V DC power.</p>
F7_F707_F708 is unable to connect with PC	<p><b>Cause:</b> Connection may be loose.</p> <p><b>Fix:</b> Check that the RS232/RS485 or Ethernet connections are secure. Also make sure network/firewall settings are not blocking communication to the F7_F707_F708</p>
LCD displays “Please try again”.	<p><b>Cause:</b> The F7_F707_F708’s fingerprint sensor may have accumulated excess dirt or scratches over a period of time. This message indicates the sensor is unable to obtain a clear image of the fingerprint. Other possible cause may be fingerprint sensor cable has loosened from circuit board.</p> <p><b>Fix:</b> Try using cellophane tape to remove dirt. Sensor may also need to be repaired/replaced.</p>
F7_F707_F708 starts up, but cannot enter menu system	<p><b>Cause:</b> Fingerprint sensor cable is loose. Fingerprint sensor is broken. Circuit board is broken.</p> <p><b>Fix:</b> Remove and plug back in Fingerprint sensor cable.</p>



<p>Time continually displays “00:00” after restarting</p>	<p><b>Cause:</b> The clock battery is drained. <b>Fix:</b> Replace battery.</p>
<p>The fingerprint sensor light is off</p>	<p><b>Cause:</b> Fingerprint sensor or flat connection cable is loose or broken. <b>Fix:</b> Unplug the cable from the fingerprint sensor and plug it back in again.</p>
<p>Pressing buttons no longer makes sound.</p>	<p><b>Cause:</b> Trouble in the buzzer, loudspeaker or circuit. <b>Fix:</b> Need to replace the buzzer and loudspeaker.</p>
<p>Some users’ fingerprints sometimes can’t be verified.</p>	<p><b>Cause:</b> The fingerprint quality is poor. <b>Fix:</b> If repeated attempts with the same finger fail, try using a different finger when enrolling. Also reduce fingerprint “threshold” setting. If user’s fingerprints completely unreadable, assign them a PIN number, instead.</p>